



Armstrong® DS Series Drain Separators

Condensate in steam and air piping reduce thermal efficiency, cause water hammer, corrode equipment such as valves and pipes, and cause other problems.

Armstrong drain separators separate condensate efficiently by using the centrifugal force of steam or air created by introducing it into a specifically shaped path. Because of the simple structure of the drain separators, pressure loss is minimized, enabling clean, dry steam or air to be fed to equipment.

With correct sizing and proper drainage, the separators are designed to eliminate 98% of all entrained liquids and particles that are 10 microns and larger in size.

Features

- A cyclone structure maximizes liquid separation efficiency
- Pressure loss is extremely low
- No moving parts means no breakdowns

Operating Principle

When steam or air flow enters the drain separator, centrifugal force is generated in the fluid because of the device's internal structural design. The fluid drains along the wall because of the difference in specific gravity with steam or air, eventually striking the baffle. The baffle guides the fluid to the drain outlet and to the trap, which drains it. As a result, both small dirt particles and condensate are separated and removed from the system through the bottom drain.

For fully certified drawings refer to:
 DS-1 / DS-2 CDY1102
 DS-3 CD2126
 DS-4 CD2127

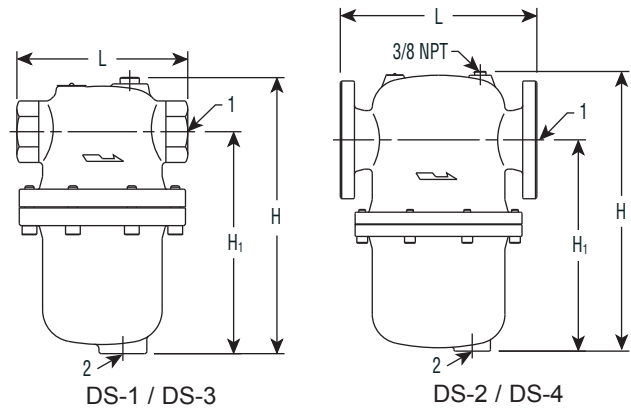

DS Series Specifications					
Model	Application	Maximum Pressure psig (bar)	Maximum Temp. °F (°C)	Materials	
				Body	Nozzle
DS-1	Steam Air	NPT 300 (20)	430 (221)	Ductile Iron ASTM A536	Cast Iron ASTM A48
DS-2		150 lb. Flanged 185 (13)			
		300 lb. Flanged 300 (20)			
DS-3		NPT 300 (20)	650 (343)	Carbon Steel SA-106-B	
DS-4	150 lb. Flanged 150 (10)	450 (232)			
	300 lb. Flanged 500 (34)	650 (343)			

DS Series Dimension and Weights

Model	Size		Face-to-Face "L"						H		H ₁		Drain		Weight					
			NPT		150#		300#								NPT		150#		300#	
	in	mm	in	mm	in	mm	in	mm	in	mm	in	mm	in	mm	lb	kg	lb	kg	lb	kg
DS-1	1/2	15	5-15/16	150	—	—	—	—	9-9/16	243	7-5/8	193	3/4	20	16	7.3	—	—	—	—
	3/4	20	5-15/16	150	—	—	—	—	9-9/16	243	7-5/8	193	3/4	20	16	7.3	—	—	—	—
	1	25	5-15/16	150	—	—	—	—	9-9/16	243	7-5/8	193	3/4	20	16	7.3	—	—	—	—
	1-1/4	32	7-1/2	190	—	—	—	—	11-1/8	243	8-3/8	213	1	25	28	12.7	—	—	—	—
	1-1/2	40	7-1/2	190	—	—	—	—	11-1/8	243	8-3/8	213	1	25	28	12.7	—	—	—	—
	2	50	8-5/8	219	—	—	—	—	13-15/32	243	10-1/4	260	1	25	45	20.5	—	—	—	—
DS-2	2-1/2	65	—	—	11-1/2	292	11-15/16	303	16-15/32	418	12-3/8	314	1	25	—	—	45	20.5	77	35
	3	80	—	—	13-1/2	343	13	356	19	484	14-1/2	361	1-1/4	32	—	—	77	35	99	45
	4	100	—	—	15-13/16	402	16-7/16	418	23-3/8	594	17-1/2	445	1-1/4	32	—	—	99	45	143	65
DS-3 NPT	1/2	15	5-1/2	140	9	229	9	229	16	356	9	229	1	25	28	12.7	30	13.6	32	14.5
	3/4	20	5-1/2	140	9	229	9	229	16	356	9	229	1	25	28	12.7	30	13.6	32	14.5
	1	25	6-3/8	162	10-1/2	267	10-1/2	267	16	356	10-1/2	267	1	25	30	13.6	33	15	35	15.9
	1-1/4	32	6-3/8	162	10-1/2	267	10-1/2	267	16	356	10-1/2	267	1	25	32	14.5	35	15.9	37	16.8
	1-1/2	40	7-5/8	194	11-1/2	292	11-1/2	292	19	483	12-1/2	318	1	25	46	20.9	50	22.7	56	25.4
	2	50	7-7/8	200	11-1/2	292	11-1/2	292	19	483	12-1/2	318	1	25	51	23.1	55	24.9	59	26.8
DS-4 Flanged	2-1/2	65	—	—	16	406	16	406	22	559	15	381	1	25	—	—	100	45.4	110	49.9
	3	80	—	—	18	457	18	457	26	660	18	457	1	25	—	—	140	63.5	150	68
	4	100	—	—	20	508	20	508	31	787	22	559	1-1/2	40	—	—	195	88.4	220	99.8
	6	150	—	—	24	610	24	610	41	1041	30	762	1-1/2	40	—	—	350	159	380	172
	8	200	—	—	28	711	28	711	50	1270	37	940	2	50	—	—	475	215	610	278
	10	250	—	—	34	864	34	864	70	1778	55	1397	2	50	—	—	780	354	1180	535
	12	300	—	—	38	965	38	965	75	1905	58	1473	2-1/2	65	—	—	940	426	1510	685

All dimensions and weights are approximate. Use certified print for exact dimensions. Design and materials are subject to change without notice.

DS Series Drain Separators



Capacities for Steam Service

DS Series Steam Capacities (lb/hr)									
Size	5 psig	10 psig	25 psig	50 psig	100 psig	150 psig	200 psig	250 psig	300 psig
1/2"	34	43	69	113	200	287	374	461	548
3/4"	60	75	121	198	351	503	656	809	962
1"	98	122	197	320	568	816	1,063	1,311	1,559
1-1/4"	169	212	340	555	983	1,412	1,840	2,269	2,698
1-1/2"	230	288	463	755	1,338	1,922	2,505	3,088	3,672
2"	379	475	763	1,244	2,206	3,167	4,129	5,090	6,052
2-1/2"	541	678	1,089	1,775	3,147	4,519	5,891	7,263	8,635
3"	835	1,046	1,682	2,741	4,860	6,978	9,096	11,215	13,333
4"	1,437	1,802	2,896	4,720	8,368	12,016	15,664	19,312	22,960
6"	3,262	4,090	6,573	10,712	18,991	27,269	35,548	43,826	52,105
8"	5,648	7,082	11,382	18,550	32,885	47,220	61,556	75,891	90,226
10"	8,903	11,162	17,941	29,239	51,835	74,430	97,026	119,622	142,218
12"	12,769	16,010	25,732	41,936	74,344	106,752	139,160	171,568	203,977

DS Series Steam Capacities (kg/hr)									
Size	0.34 bar	0.69 bar	1.7 bar	3.4 bar	6.9 bar	10.3 bar	13.8 bar	17.2 bar	20.7 bar
1/2"	16	20	31	51	91	130	170	209	249
3/4"	27	34	55	90	159	228	298	367	436
1"	44	55	89	145	258	370	482	595	707
1-1/4"	77	96	154	252	446	640	835	1,029	1,224
1-1/2"	104	131	210	342	607	872	1,136	1,401	1,665
2"	172	215	346	564	1,001	1,437	1,873	2,309	2,745
2-1/2"	245	307	494	805	1,428	2,050	2,672	3,294	3,917
3"	379	475	763	1,243	2,204	3,165	4,126	5,087	6,048
4"	652	817	1,314	2,141	3,796	5,450	7,105	8,760	10,414
6"	1,480	1,855	2,982	4,859	8,614	12,369	16,124	19,880	23,635
8"	2,562	3,212	5,163	8,414	14,917	21,419	27,921	34,424	40,926
10"	4,038	5,063	8,138	13,263	23,512	33,761	44,011	54,260	64,509
12"	5,792	7,262	11,672	19,022	33,722	48,423	63,123	77,823	92,523

Piping/Installation

Always mount the drain separator in a horizontal pipe, with the drain discharge port facing downward. Be sure to install a trap device below the drain discharge port. The top of the trap should be lower than the separator's drain discharge port.

Typical Installation for Steam Application

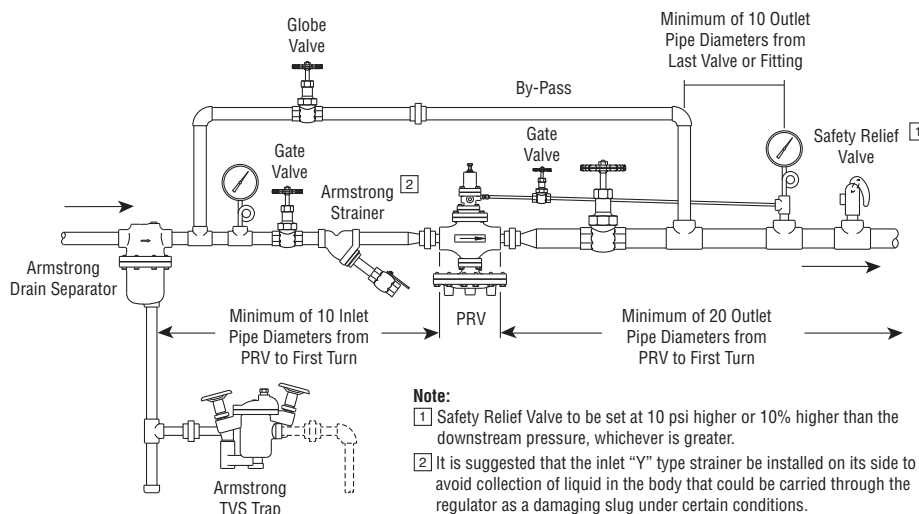

Ancillary Products