



Armstrong® TVS 800 Series Cast Iron Trap Valve Station

Steam Trapping and
Steam Tracing Equipment

Put the principle of the inverted bucket to work in a tough cast iron package and you have the best of both worlds—energy efficiency and long-lasting reliability. Add the advantages of valves integrated into one compact trap/valve casting, and you extend the benefits into installation, trap testing and maintenance.

All the components are concentrated in a single, accessible package and can be dealt with in-line. And if you have existing Armstrong cast iron traps in-line, identical face-to-face dimensions will make retrofitting with the patented* Armstrong Trap Valve Station (TVS) a snap. You'll also reduce your inventory requirements. So you'll eliminate what you're paying just to keep parts on hand.

Integral isolation valves

Rugged cast iron package

Reduced costs

TVS saves on these fronts: energy, installation and maintenance.

Integration of trap and valves

Inverted bucket long life and energy efficiency, plus the savings and convenience of components merged into one space-saving package.

A full range of options

TVS will accommodate a test valve, strainer, internal check valve, thermic vent bucket, TrapAlert™ and SteamEye®—remote steam trap monitoring system for steam traps.

Easy, in-line repairability

Elimination of potential leak points

Reduced design time

Permits combining products with exact face-to-face dimensions.

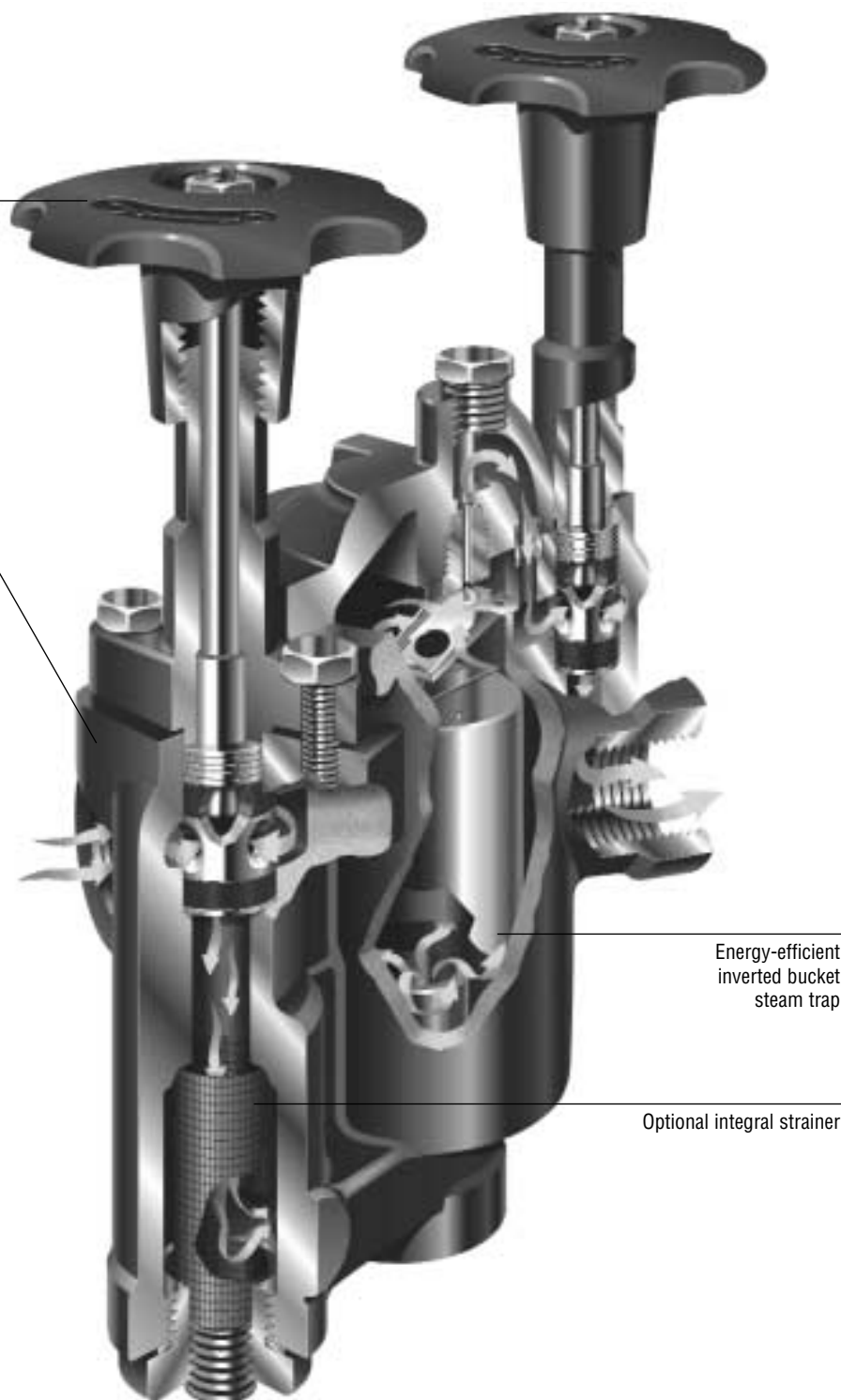

Energy-efficient
inverted bucket
steam trap

Optional integral strainer

*U.S. Patent 5,947,145

TVS 800 Series Cast Iron Trap Valve Station



Steam Trapping and Steam Tracing Equipment

TVS makes a long story...short.

Typical Installation

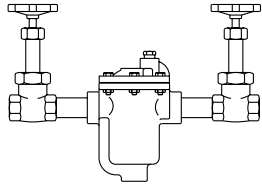

Inverted bucket trap with two isolation valves

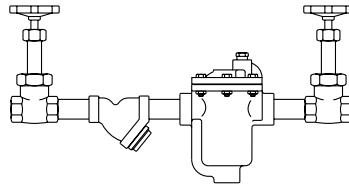

Inverted bucket trap with two isolation valves and strainer

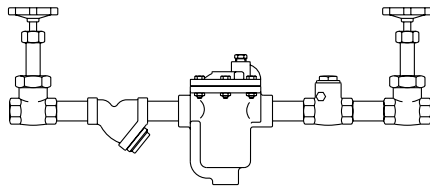

Inverted bucket trap with two isolation valves, strainer and check valve

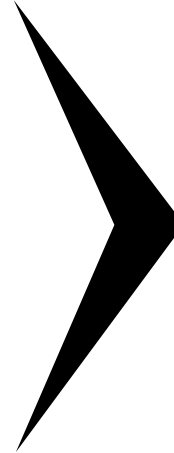

Trap Valve Station



The Innovation Is Integration

The Armstrong TVS makes what used to be long, complicated steam installation stories simple and compact. It shortens installations by integrating components—specifically an inverted bucket steam trap with two or more valves.

this steam story: *pipe-TVS-pipe*. In other words, the TVS makes it all one, delivering the functions of multiple components in a dramatically smaller unit. It integrates two high-value products in a package of revolutionary versatility.

For example, here's an old description for a typical installation: *valve-nipple-strainer-nipple-trap-nipple-valve*. It's a long tale, even for this simple piping arrangement. The Trap Valve Station rewrites

Look above to see how the Armstrong cast iron Trap Valve Station has rewritten these typical steam installations.

Average Service Life for Different Trap Types 200 psi (14 bar)

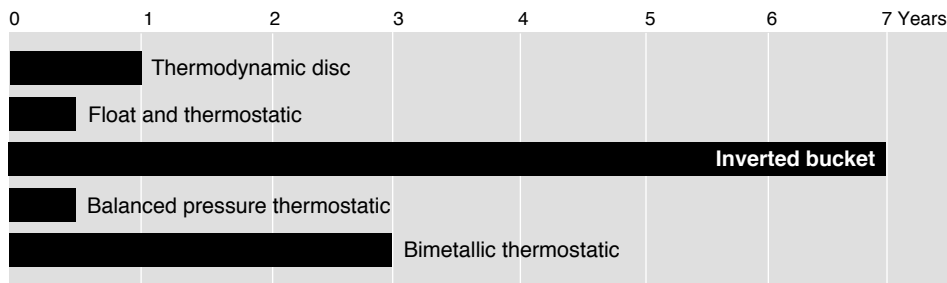

Above data from *ICI Engineer* January 1993 special issue with permission from ICI Engineering.



TVS 800 Series Trap Valve Station

Cast Iron for Horizontal Installation, With Integral Piston Valves

For Pressures to 250 psig (17 bar)...Capacities to 4,400 lb/hr (2,000 kg/hr)

Steam Trapping and Steam Tracing Equipment

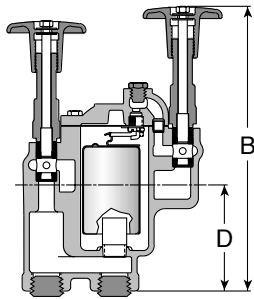

Model TVS 811

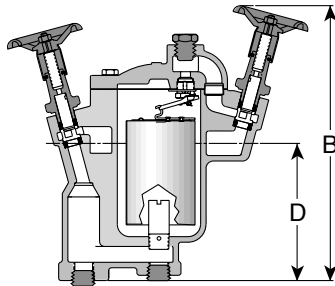

Series TVS 812/813

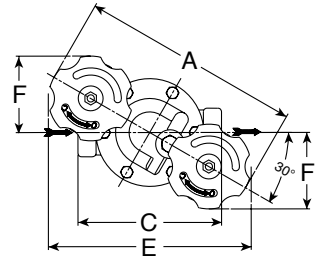

Series TVS 811/812/813 - Top View

Same principle. Different package. Now the energy-saving performance and reliability of the inverted bucket steam trap are available in a versatile new package.

You'll still enjoy all the familiar benefits. And the same efficient condensate drainage from virtually every kind of steam-using equipment. But what you'll find new are all the benefits of a piston valve integrated into the same space-saving package.

Maximum Operating Conditions

Maximum allowable pressure (vessel design): 250 psig @ 450°F (17 bar @ 232°C)
 Maximum operating pressure: 250 psig (17 bar)

Connections

Screwed NPT and BSPT

Materials

Cap and body: ASTM A48 Class 30
 Internals: All stainless steel—304
 Valve and seat: Hardened chrome steel—440F
 Piston valve handle: Cast iron ASTM A47
 Internals: Stainless steel
 Valve sealing rings: Graphite and stainless steel
 Blowdown valve: Stainless steel

Options

- Stainless steel internal check valve
- Thermic vent bucket
- Stainless steel pop drain
- Integral strainer
- Scrub wire
- Probe connection
- Blowdown valve (TVS 811 and TVS 812 only)

Specification

Inverted bucket steam trap, type ... in cast iron, with continuous air venting at steam temperature, free-floating stainless steel mechanism, and discharge orifice at the top of the trap. Integral upstream and downstream shutoff piston style valves in same dimensional space as standard bucket trap.

How to Order

- Specify:
- Model number
 - Size and type of pipe connection
 - Maximum working pressure that will be encountered or orifice size
 - Any options required

For a fully detailed certified drawing, refer to:

TVS 811 CD #1099
 TVS 812/813 CD #1100

TVS 800 Series Trap Valve Station						
Model No.	TVS 811		TVS 812		TVS 813	
	in	mm	in	mm	in	mm
Pipe Connections	1/2, 3/4	15, 20	1/2, 3/4	15, 20	3/4, 1	20, 25
Test Plug	1/4	6	1/2	15	3/4	20
"A" Width Across Handwheels	7-3/4	197	13-3/4	349	15-1/8	384
"B" Outlet Valve Open	10	254	11-3/4	298	14-1/4	362
"C" Face to Face	5	127	6-1/2	165	7-3/4	197
"D" Connection \varnothing to Bottom	3-3/4	94	4-3/4	121	7-1/4	184
"E"	7-1/16	179	13	330	14-3/8	365
"F"	2-11/16	68	4-1/2	114	4-7/8	124
Number of Bolts	6	6	6	6	6	6
Weight lb (kg)	12	5.4	25	11.3	47	24

All dimensions and weights are approximate. Use certified print for exact dimensions. Design and materials are subject to change without notice.

TVS 800 Series Trap Valve Station

Cast Iron for Horizontal Installation, With Integral Piston Valves

For Pressures to 250 psig (17 bar)...Capacities to 4,400 lb/hr (2,000 kg/hr)



Steam Trapping and
Steam Tracing Equipment

Model TVS 811 Capacity

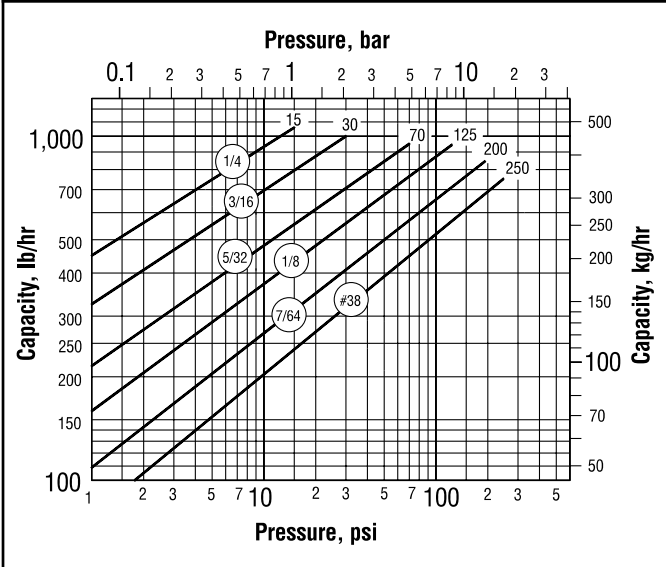

Model TVS 812 Capacity

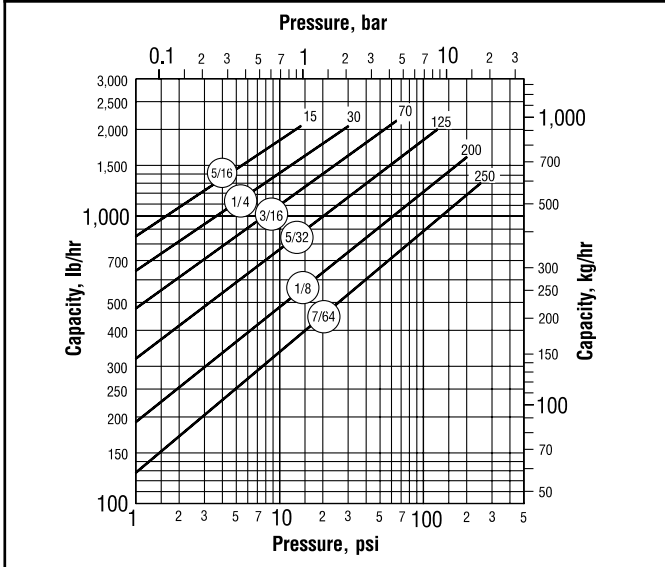

Model TVS 813 Capacity

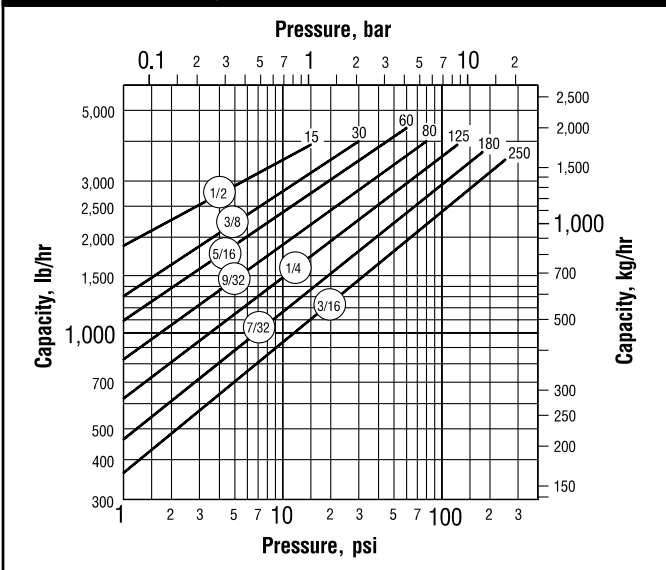

Options

Internal Check Valves are spring-loaded stainless steel and screw directly into the trap inlet or into an extended inlet tube having a pipe coupling at the top to save fittings, labor and money.

Thermic Vent Buckets have a bimetal controlled auxiliary air vent for discharging large amounts of air on start-up.

Integral Strainer is made from 20 x 20 stainless steel screen.

Probe Connections are available for trap monitoring.

Blowdown Valve for clearing strainers of dirt and debris.

