

GP-1000



For Steam, Air and Non-Corrosive Gas

The GP-1000 Series valves are pilot-controlled for accurate regulation of pressure under wide-ranging flow. Internal pilot design eliminates external components and piping.

Internally piloted GP Series valves are capable of larger capacity and greater accuracy than direct acting valves.

Completely supported by piping, lightweight GP Series valves install easily with NPT or flanged connections. A stainless steel diaphragm, hardened stainless steel working parts and integral removable strainer team up to provide

high performance over a long, trouble-free service life. Valves are equipped with a single seated main valve, piston valve rings for longer life and an external adjusting screw with locking nut. All working parts are renewable in-line. ANSI Class IV Shutoff.

For a fully detailed certified drawing, refer to list below.

GP-1000 NPT	CD #2104
GP-1000 Flanged	CD #2105
GP-1000 SS/AS	CDY #1081

GP-1000											
Model Number	Pressure		Spring Color	Application	Maximum Temp. °F (°C)	Minimum Diff. psig (bar)	Body	Main Valve/ Valve Seat	Pilot Valve/Seat	Piston/Cylinder	Diaphragm
	Inlet psig (bar)	Reduced psig (bar)									
NPT GP-1000	15 - 250 (1 - 17)	5 - 125 (.34 - 8.6)	Black	Steam	450 (232)	7 (.48)	Ductile Iron ASTM A536	Stainless Steel AISI 420	Stainless Steel AISI 403/420	Stainless Steel AISI 420/Stainless Steel AISI 403	Stainless Steel AISI 301
		125 - 200 (8.6 - 13.8)	Green								
150 ANSI GP-1000	15 - 150 (1 - 10)	5 - 125 (.34 - 8.6)	Black	Air & Gas	175 (80)	7 (.48)	Ductile Iron ASTM A536	Stainless Steel AISI 420/ Brass w/NBR	Stainless Steel AISI 403/420	Bronze/Bronze ASTM C36000	Stainless Steel AISI 301
NPT GP-1000A	15 - 150 (1 - 10)	5 - 125 (.34 - 8.6)									
150 ANSI GP-1000A	15 - 150 (1 - 10)	5 - 125 (.34 - 8.6)									
GP-1000SS* GP-1000AS*	15 - 150 (1 - 10)	5 - 125 (.34 - 8.6)		Steam	450 (232)		Stainless Steel AISI 304	Stainless Steel AISI 420	Stainless Steel AISI 403/420	Stainless Steel AISI 420/Stainless Steel AISI 403	

Pressure and Temperature Controls

NOTES: Sizes 2" (50 mm) and below are NPT connections. Sizes 2" (50 mm) and larger are flanged connections. Model GP-1000 is available with air-loaded pilots. Consult factory. Turndown ratio for GP-1000 20:1. *GP-1000SS/GP-1000AS are available in 1/2" - 2" only and are flanged with NPT companion flanges.

Symbol	Connection Size																			
	in		mm		in		mm		in		mm		in		mm		in		mm	
	1/2	15	3/4	20	1	25	1-1/4	32	1-1/2	40	2*	50	2-1/2	65	3	80	4	100		
L	5-7/8	150	6-1/8	155	6-5/16	160	7-1/2	190	7-1/2	190	8-11/16	220	9-5/8	245	11-3/8	290	13	330		
H	11-1/4	285	11-1/4	285	11-7/8	300	12-3/4	323	12-3/4	323	13-5/8	347	14	357	15-7/8	404	17-3/4	450		
H ₁	2-1/2	64	2-1/2	64	2-5/8	67	3-1/4	82	3-1/4	82	3-11/16	93	4	100	4-13/16	122	5-9/16	144		
Wt, lb (kg)	15-1/2 (7)		15-1/2 (7)		19 (8.5)		25-1/2 (12)		27-1/2 (12.5)		40 (18)		66 (30)		77 (35)		116 (53)			
C _v	1		2.3		4		6.5		9		16		25		36		64			

NOTES: GP-1000 is 1/2"-2" (20-50 mm) NPT, 2"- 4" (50-100 mm) ANSI 150 lb flanged. * "L" Dimension for 2" 150# flange is 8-11/16" (220 mm).



GP-1000

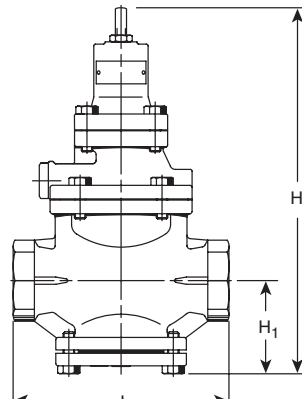

GP-1000 NPT 1/2" - 2"

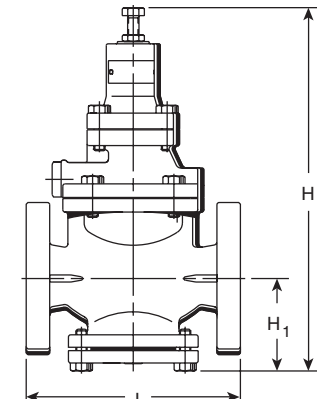

GP-1000 150 FL 2" - 4"

Designs, materials, weights and performance ratings are approximate and subject to change without notice. Visit www.armstronginternational.com for up-to-date information.

Capacities for Steam, Air and Non-Corrosive Gas

GP-1000 Capacities—Steam										
Inlet	Outlet	lb/hr								
		Connection Size								
		in								
psig		1/2	3/4	1	1-1/4	1-1/2	2	2-1/2	3	4
C _v Factor		1	2.3	4	6.5	9	16	25	36	64
15	8	40	93	161	261	362	644	1,005	1,448	2,574
	5	47	107	187	303	420	747	1,167	1,680	2,987
20	13	44	101	176	285	395	702	1,097	1,580	2,809
	5	60	138	240	390	540	960	1,500	2,160	3,839
30	23	50	116	202	328	454	807	1,261	1,816	3,228
	5 - 7	76	176	306	497	688	1,223	1,911	2,752	4,892
40	33	56	129	225	365	506	900	1,406	2,024	3,598
	25	79	182	316	514	711	1,264	1,976	2,845	5,057
50	5 - 12	94	215	374	608	842	1,497	2,338	3,367	5,986
	42	65	151	262	425	589	1,047	1,636	2,356	4,188
75	30	98	226	393	638	884	1,572	2,456	3,536	6,287
	5 - 17	111	254	443	719	996	1,770	2,766	3,983	7,081
100	63	94	216	376	612	847	1,506	2,353	3,388	6,024
	45	141	323	562	914	1,265	2,249	3,515	5,061	8,998
125	5 - 30	153	353	614	997	1,380	2,454	3,835	5,522	9,817
	85	119	274	476	774	1,072	1,905	2,977	4,287	7,622
150	70	162	374	650	1,056	1,462	2,599	4,061	5,847	10,395
	5 - 42	196	451	785	1,275	1,765	3,138	4,903	7,061	12,553
175	106	148	340	591	960	1,329	2,363	3,693	5,318	9,454
	100	167	385	670	1,089	1,507	2,680	4,187	6,029	10,718
200	75	225	517	900	1,462	2,024	3,598	5,623	8,097	14,394
	7 - 55	239	549	956	1,553	2,150	3,822	5,972	8,600	15,289
225	125	183	421	733	1,191	1,649	2,931	4,580	6,595	11,724
	100	248	571	993	1,613	2,234	3,971	6,205	8,936	15,885
250	80	283	651	1,132	1,839	2,547	4,528	7,074	10,187	18,111
	8 - 67	282	648	1,127	1,831	2,535	4,506	7,041	10,139	18,025
175	148	205	471	819	1,331	1,844	3,277	—	—	—
	125	270	620	1,078	1,752	2,426	4,312	—	—	—
200	100	317	730	1,269	2,062	2,856	5,077	—	—	—
	9 - 80	324	746	1,298	2,109	2,919	5,190	—	—	—
225	170	230	529	919	1,494	2,069	3,678	—	—	—
	150	289	665	1,157	1,880	2,603	4,628	—	—	—
250	125	342	787	1,369	2,225	3,081	5,478	—	—	—
	10 - 92	367	844	1,469	2,386	3,304	5,874	—	—	—
225	191	258	594	1,034	1,680	2,326	4,135	—	—	—
	175	308	708	1,231	2,000	2,769	4,923	—	—	—
250	150	366	841	1,463	2,377	3,292	5,852	—	—	—
	12 - 105	410	943	1,640	2,664	3,689	6,558	—	—	—
250	200	325	748	1,301	2,113	2,926	5,202	—	—	—
	175	388	892	1,551	2,520	3,489	6,203	—	—	—
250	150	435	1,001	1,741	2,829	3,916	6,963	—	—	—
	13 - 117	453	1,041	1,811	2,942	4,074	7,242	—	—	—

NOTE: For air capacities scfm, multiply steam capacities lb/hr by 0.36.

Pressure and Temperature Controls

Capacities for Steam, Air and Non-Corrosive Gas

GP-1000 Capacities—Steam										
		kg/hr								
Inlet	Outlet	Connection Size								
		mm								
bar		15	20	25	32	40	50	65	80	100
C _y Factor		1	2.3	4	6.5	9	16	25	36	64
1.03	0.55	18	42	73	119	164	292	456	657	1,168
	0.34	21	49	85	138	191	339	529	762	1,355
1.38	0.90	20	46	80	129	179	319	498	717	1,274
	0.34	27	63	109	177	245	435	680	980	1,741
2.07	1.59	23	53	92	149	206	366	572	824	1,464
	.34 - .48	35	80	139	225	312	555	867	1,248	2,219
2.76	2.28	26	59	102	166	230	408	638	918	1,632
	1.72	36	82	143	233	323	574	896	1,290	2,294
	.34 - .83	42	98	170	276	382	679	1,061	1,527	2,715
3.45	2.90	30	68	119	193	267	475	742	1,069	1,900
	2.07	45	102	178	290	401	713	1,114	1,604	2,852
	.34 - 1.17	50	115	201	326	452	803	1,255	1,807	3,212
5.17	4.34	43	98	171	278	384	683	1,067	1,537	2,732
	3.10	64	147	255	415	574	1,020	1,594	2,296	4,081
	.34 - 2.1	70	160	278	452	626	1,113	1,739	2,505	4,453
6.89	5.86	54	124	216	351	486	864	1,350	1,945	3,457
	4.83	74	169	295	479	663	1,179	1,842	2,652	4,715
	.34 - 2.9	89	205	356	578	801	1,423	2,224	3,203	5,694
8.62	7.31	67	154	268	436	603	1,072	1,675	2,412	4,288
	6.89	76	175	304	494	684	1,215	1,899	2,735	4,862
	5.17	102	235	408	663	918	1,632	2,550	3,673	6,529
	.48 - 3.7	108	249	433	704	975	1,734	2,709	3,901	6,935
10.00	8.62	83	191	332	540	748	1,330	2,077	2,991	5,318
	6.89	113	259	450	732	1,013	1,801	2,815	4,053	7,206
	5.52	128	295	513	834	1,155	2,054	3,209	4,621	8,215
	.55 - 4.6	128	294	511	830	1,150	2,044	3,194	4,599	8,176
12.07	10.20	93	214	372	604	836	1,487	—	—	—
	8.62	122	281	489	795	1,100	1,956	—	—	—
	6.89	144	331	576	936	1,295	2,303	—	—	—
	.62 - 5.5	147	338	589	956	1,324	2,354	—	—	—
13.79	11.72	104	240	417	678	938	1,668	—	—	—
	10.34	131	302	525	853	1,181	2,099	—	—	—
	8.62	155	357	621	1,009	1,398	2,485	—	—	—
	.68 - 6.3	167	383	666	1,082	1,499	2,665	—	—	—
15.51	13.17	117	270	469	762	1,055	1,876	—	—	—
	12.07	140	321	558	907	1,256	2,233	—	—	—
	10.34	166	382	664	1,078	1,493	2,654	—	—	—
	.82 - 7.24	186	428	744	1,209	1,673	2,975	—	—	—
17.24	13.79	147	339	590	959	1,327	2,360	—	—	—
	12.07	176	404	703	1,143	1,583	2,814	—	—	—
	10.34	197	454	790	1,283	1,776	3,158	—	—	—
	.89 - 8.06	205	472	821	1,335	1,848	3,285	—	—	—

Pressure and Temperature Controls

For air capacities m³/hr, multiply steam capacities kg/hr by 1.35.