

For Steam Service

The GP-2000 is a high performance, externally piloted reducing valve for large capacity requirements. Typical use is on intermittent service, including applications such as heat exchangers, steam coils, rotating dryers, process equipment and heating systems. With a 20:1 rangeability and high C_v , the GP-2000 is reliable and accurate (+/-1% of pressure set point from 5% to 100% of flow) over a long, trouble-free service life. Hardened stainless steel working parts

are renewable in-line. Single seated for dead-end service. Available with both NPT (1/2" - 2") and flanged connections in 1/2" - 6" sizes. ANSI Class IV Shutoff.

For a fully detailed certified drawing, refer to:
GP-2000 CDY #1008
GP-2000 Flanged CDY #1007

Pressure and Temperature Controls

GP-2000 Specifications										
Application	Inlet Pressure psig (bar)	Reduced Pressure psig (bar)	Spring Color	Maximum Temperature °F (°C)	Minimum Differential psig (bar)	Materials				
						Body	Main Valve/Seat	Pilot Valve/Seat	Diaphragm	Color
Steam	NPT 15 - 300 (1 - 20)	*1.5 - 3 (.10 - .21) 3 - 21 (.21 - 1.4) 15 - 200 (1 - 13.8)	Yellow Yellow Green	450 (232)	7 (.48)	Ductile Iron ASTM A536	Stainless Steel AISI 420	Stainless Steel AISI 301	Dark Gray	
	15 - 185 (1 - 13) 150 lb. Flanged									
	15 - 300 (1 - 20) 300 lb. Flanged									

*NOTE: When using this spring range, remove one (1) pilot diaphragm. Capacities are reduced by 1/2 of capacity chart when this spring is being used.

GP-2000 Dimensions and Weights																										
Size	Face-to-Face "L"						A	F	H Integral		H Remote		H ₁		H ₂		Weight						C _v *			
	NPT		150#		300#				in	mm	in	mm	in	mm	in	mm	in	mm	lb	kg	lb	kg		lb	kg	
1/2	15	5-15/16	150	5-9/16	141	5-3/4	147	7-15/16	200	6-7/8	176	15-3/4	398	14-1/4	362	6-3/4	170	9-5/8	244	34	14	36	15	42	19	5.0
3/4	20	5-15/16	150	5-1/2	140	5-3/4	147	7-15/16	200	6-7/8	176	15-3/4	398	14-1/4	362	6-3/4	170	9-5/8	244	34	14	36	15	42	19	7.2
1	25	6-5/16	160	5-3/4	147	6-1/4	159	8-15/16	226	7-1/16	179	15-15/16	404	14-7/16	367	6-15/16	175	10	254	44	19	48	20	54	23	10.9
1-1/4	32	7-1/8	180	6-1/2	166	7-1/16	179	8-15/16	226	7-7/16	188	17-1/8	434	15-1/8	384	7-5/8	192	11-1/8	283	51	22	53	22	59	25	14.3
1-1/2	40	7-1/8	180	7-7/16	189	7-15/16	202	8-15/16	226	7-7/16	188	17-1/8	434	15-1/8	384	7-5/8	192	11-1/8	283	51	22	55	23	61	26	18.8
2	50	9-1/8	230	8-9/16	217	9-1/8	232	10-15/16	276	7-11/16	195	19-5/8	498	16	406	8-1/2	216	12-5/8	321	75	33	81	36	84	36	32
2-1/2	65	-	-	10-15/16	278	11-1/2	292	13-13/16	352	8-5/16	211	21-3/4	552	17-5/16	440	9-13/16	251	14-3/4	375	-	-	142	65	150	65	60
3	80	-	-	11-3/4	298	12-7/16	315	13-13/16	352	8-3/4	222	22-5/8	575	17-15/16	456	10-7/16	264	15-3/4	400	-	-	155	69	166	72	78
4	100	-	-	13-1/2	343	14-1/8	359	15-13/16	401	9-7/16	239	25-15/16	658	20-1/8	511	12-5/8	321	19-1/4	489	-	-	247	112	264	119	120
6	150	-	-	18-1/8	460	19	483	19-3/4	502	-	-	31-3/4	806	-	-	16-1/4	414	26-1/2	673	-	-	507	230	553	252	250

*50% reduced port available for sizes 1/2" - 4". The C_v value should be divided by 2 to get reduced port C_v.

For capacities see page 299.

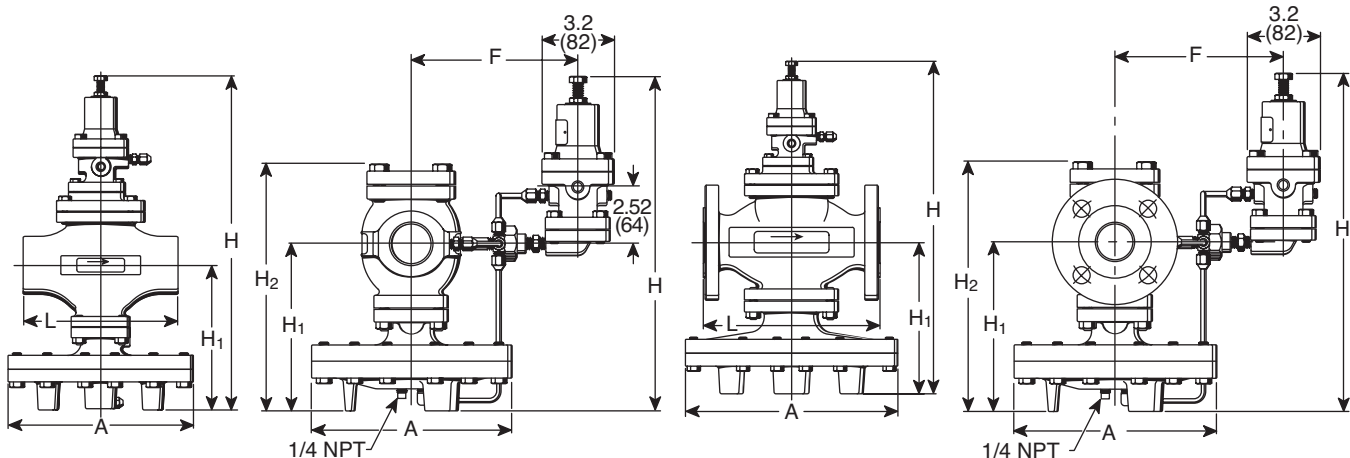

GP-2000L



For Steam Service

The GP-2000L is a high performance, externally piloted reducing valve for large capacity and low inlet pressure requirements. The GP-2000L is reliable and accurate (+/-1% of pressure set point from 5% to 100% of flow) over a long, trouble-free service life. Hardened stainless steel working

parts are renewable in-line. Single seated for dead-end service. Available with both NPT (1/2" - 2") and flanged connections in 1/2" - 4" sizes. ANSI Class IV Shutoff.

GP-2000L Specifications						Materials				
Application	Inlet Pressure psig (bar)	Reduced Pressure psig (bar)	Spring Color	Maximum Temperature °F (C)	Minimum Differential psig (bar)	Body	Main Valve/Seat	Pilot Valve/Seat	Diaphragm	Color
						Steam	5 - 15 (.3 - 1)	2 - 12 (.13 - .8)	Yellow	450 (232)

GP-2000L Dimensions and Weights																											
Size	Face-to-Face "L"						A	F	H Integral	H Remote	H ₁	H ₂	Weight						C _v *								
	NPT		150#		300#								NPT		150#		300#										
in	mm	in	mm	in	mm	in	mm	in	mm	in	mm	in	mm	in	mm	in	mm	in	mm	lb	kg	lb	kg	lb	kg	lb	kg
1/2	15	5-15/16	150	5-9/16	141	5-3/4	147	7-15/16	200	6-7/8	176	15-3/4	398	14-1/4	362	6-3/4	170	9-5/8	244	34	14	36	15	42	19	5.0	
3/4	20	5-15/16	150	5-1/2	140	5-3/4	147	7-15/16	200	6-7/8	176	15-3/4	398	14-1/4	362	6-3/4	170	9-5/8	244	34	14	36	15	42	19	7.2	
1	25	6-5/16	160	5-3/4	147	6-1/4	159	8-15/16	226	7-1/16	179	15-15/16	404	14-7/16	367	6-15/16	175	10	254	44	19	48	20	54	23	10.9	
1-1/4	32	7-1/8	180	6-1/2	166	7-1/16	179	8-15/16	226	7-7/16	188	17-1/8	434	15-1/8	384	7-5/8	192	11-1/8	283	51	22	53	22	59	25	14.3	
1-1/2	40	7-1/8	180	7-7/16	189	7-15/16	202	8-15/16	226	7-7/16	188	17-1/8	434	15-1/8	384	7-5/8	192	11-1/8	283	51	22	55	23	61	26	18.8	
2	50	9-1/8	230	8-9/16	217	9-1/8	232	10-15/16	276	7-11/16	195	19-5/8	498	16	406	8-1/2	216	12-5/8	321	75	33	81	36	84	36	32	
2-1/2	65	-	-	10-15/16	278	11-1/2	292	13-13/16	352	8-5/16	211	21-3/4	552	17-5/16	440	9-13/16	251	14-3/4	375	-	-	142	65	150	65	60	
3	80	-	-	11-3/4	298	12-7/16	315	13-13/16	352	8-3/4	222	22-5/8	575	17-15/16	456	10-7/16	264	15-3/4	400	-	-	155	69	166	72	78	
4	100	-	-	13-1/2	343	14-1/8	359	15-13/16	401	9-7/16	239	25-15/16	658	20-1/8	511	12-5/8	321	19-1/4	489	-	-	247	112	264	119	120	

*50% reduced port available for sizes 1/2" - 4". The C_v value should be divided by 2 to get reduced port C_v.

For capacities see page 309.

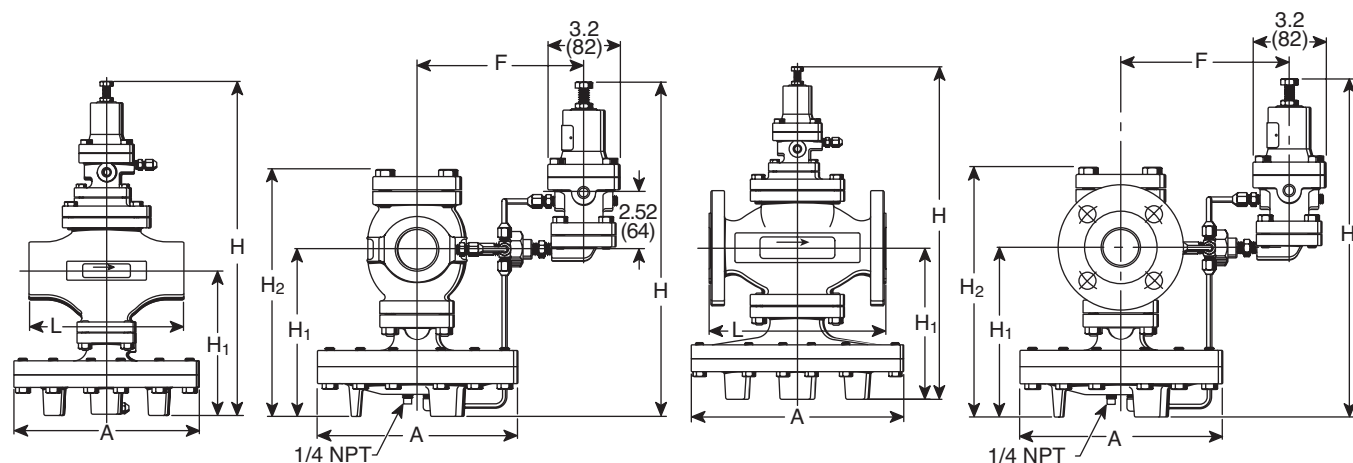

Designs, materials, weights and performance ratings are approximate and subject to change without notice. Visit www.armstronginternational.com for up-to-date information.